

# Mobility Aids

## Customer Handbook



### General Mobility Aid Information

Mobility aids are designed to assist individuals dealing with mobility limitations with the goal of maintaining home safety and independence.

- Mobility aids provide stability and balance for patients recovering from a temporary condition such as post-surgery or a permanent medical condition including weakness or imbalance.
- Most mobility aids require moderate strength in your hands, arms, and shoulders. Mayo Clinic Store staff will assess your condition and situation to ensure a mobility aid may be safely used in the home.
- Mobility aids may be available as a purchase or rental depending upon the type of equipment and whether the item is covered by insurance. Certain mobility products may require a provider's prescription.
- Products and services displayed in this handbook may not be available at all locations.

### Rental & Purchase Information

- For equipment covered under insurance as a rental or purchase, the Mayo Clinic Store will provide mobility aids per your provider's order and within insurance limitations. You may be financially responsible for any charges not paid by insurance which may include co-pays or deductibles.
- The Mayo Clinic Store retains ownership of all rental equipment until the rental period is complete. Once the rental period is complete, ownership of the mobility aid will transfer to the patient.
- Damaged rental equipment returned to the Mayo Clinic Store may incur additional charges.
- The Mayo Clinic Store requires a credit card on file to dispense rental equipment. The rental terms and conditions can be found on the rental agreement

### Purchase Return Policy

- Mayo Clinic Store will accept returns on most products within 30 days for a merchandise refund or exchange. Refunds will be issued via original payment method. Products beyond 30 days from the date of purchase are not returnable.
- Returned items are subject to inspection and must be in resalable condition, contain the original manuals and blank warranty cards. Any equipment deemed unsuitable for resale will not be accepted for exchange or refund.

### Warranty Information

- Mobility aid equipment is warrantied according to the manufacturer's guidelines.
- The manufacturer warranty may not be guaranteed if the product is unusable due to neglect or mistreatment.

### Service Locations

MINNESOTA	WISCONSIN	IOWA	ARIZONA
<b>Albert Lea</b> Call 507-668-2913	<b>Eau Claire</b> Call 715-838-1815	<b>Decorah</b> Call 563-382-0028	<b>Phoenix</b> Call 480-342-4830
<b>Austin</b> Call 507-434-1266	<b>La Crosse</b> Call 608-392-9797		
<b>Fairmont</b> Call 507-238-5133	<b>Menomonie</b> Call 715-838-1815		
<b>Mankato</b> Call 507-594-2689	<b>Onalaska</b> Call 608-392-9797		
<b>Owatonna</b> Call 507-444-5098			
<b>Red Wing</b> Call 651-385-3450			
<b>Rochester</b> Call 507-284-9669			

\* Mayo Clinic Store is available to assist with questions related to your walker. Normal business hours for the Mayo Clinic Stores are Monday through Friday, 8 am–5 pm. For issues that cannot wait until the next business day contact the store where you received your equipment for further assistance.

# Folding Walker

## USAGE INSTRUCTIONS

The following steps are used to adjust the walker to your height:

- 1 The walker needs to be fully locked open.
- 2 From a standing position while looking forward, stand inside the frame of the walker with arms relaxed and down at your sides.
- 3 Adjust the rubber hand grip to be approximately even with the crease in your wrist joint. This is done by depressing and resizing the walker legs using the push buttons.
- 4 Once adjusted, your elbows should be bent at least a 15-degree angle while holding the hand grips.

\*The Mayo Clinic Store team will assist with the proper fitting of your walker. If you would like more information on how to fit and navigate with your walker, please ask for more Mayo Clinic educational material.

## Folding and Unfolding the Walker

- 1 Press the release button along the top bar of the walker to unfold. If unable to press with fingers, you can use your palms to open.
- 2 Always ensure your walker is fully locked open before use.

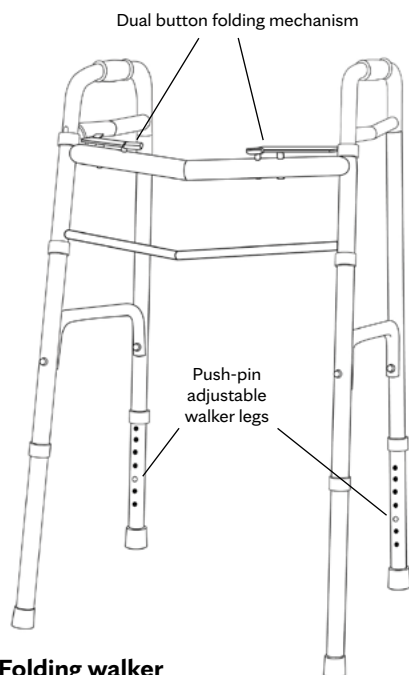

**Folding walker**

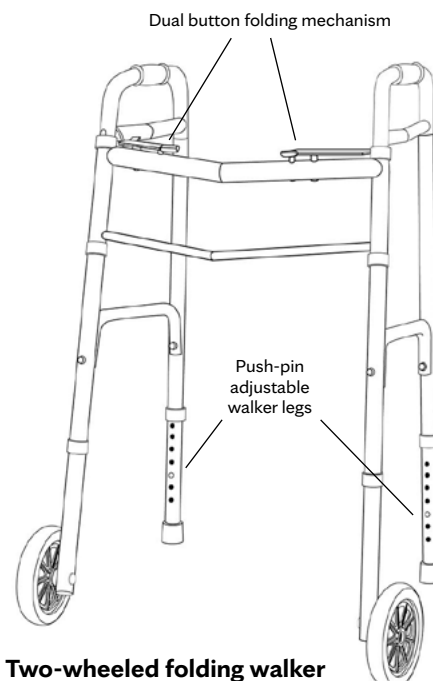

**Two-wheeled folding walker**

# Four-wheeled Walker

## USAGE INSTRUCTIONS

The following steps are used to adjust the four-wheeled walker to your height:

- 1 Lock both wheels and sit on the seat. Ensure both feet are planted on the ground. Legs should remain at a 90-degree angle to ensure safety and ease of standing up.
- 2 Standing up and facing the four-wheeled walker, grab the hand grips with both hands. Adjust hand grips to a height that leaves the arms with at least a 15-degree bend.

Four-wheeled walkers are designed to be folded and unfolded for ease of transportation.

\*The Mayo Clinic Store team will assist with the proper fitting of your four-wheeled walker. If you would like more information on how to fit and navigate with your four-wheeled walker, please ask for more Mayo Clinic educational material.

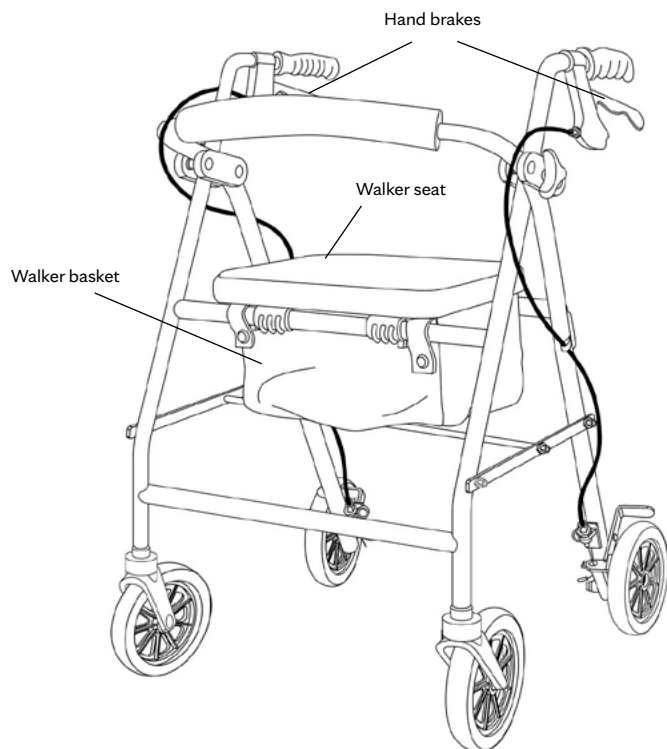

**Four-Wheeled Walker**

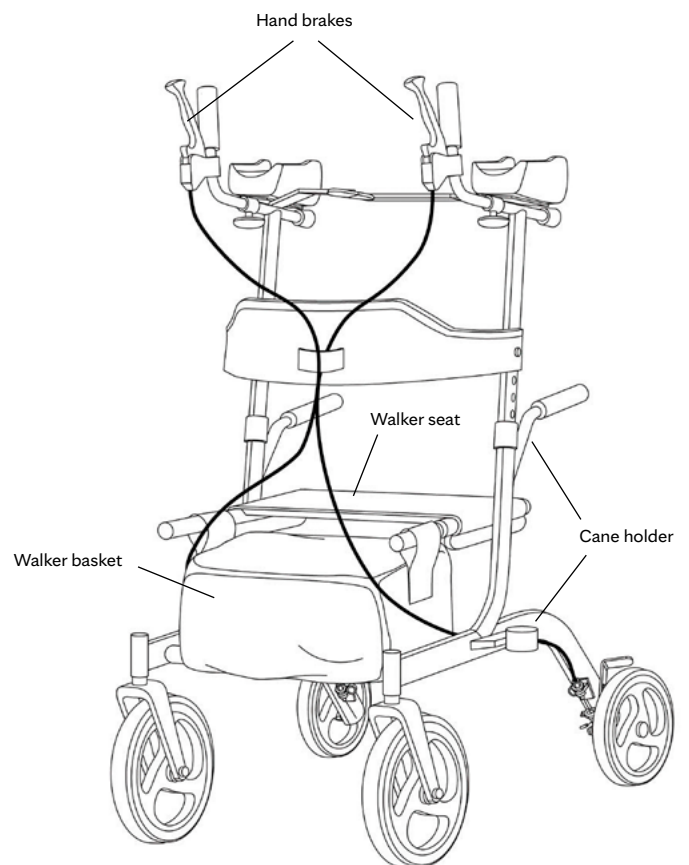

**Standing Four-Wheeled Walker**

### To Fold and Transport the Walker

- 1 Lift the seat into upright position.
- 2 Grasp the handle and bar located under the seat and pull upward (refer to Owner's Manual for product specifics).

### To Unfold and Open the Walker

- 1 Hold both handles and squeeze the hand brakes.
- 2 Hold the walker upright and rest it on the rear wheels.
- 3 Push down on both handles until all four wheels are touching the ground.
- 4 Push down on the bottom of the storage back (depends on the model) until the folding crossbar is fully engaged.

### Use the Following Steps to Sit in Your Walker

- 1 Lock the hand brakes by pushing down on the knob located at the rear of the handle until it locks in the downward position and does not roll.
- 2 Turn around inside the handles of your walker using the handles to stabilize yourself. Turn until the back of your legs are touching the seat of the walker.
- 3 Hold both hand grips and slowly lower your body onto the seat.
- 4 Make sure that your weight is evenly distributed on your seat with both feet on the ground. Leaning on either side of the walker while seated may cause it to tip.

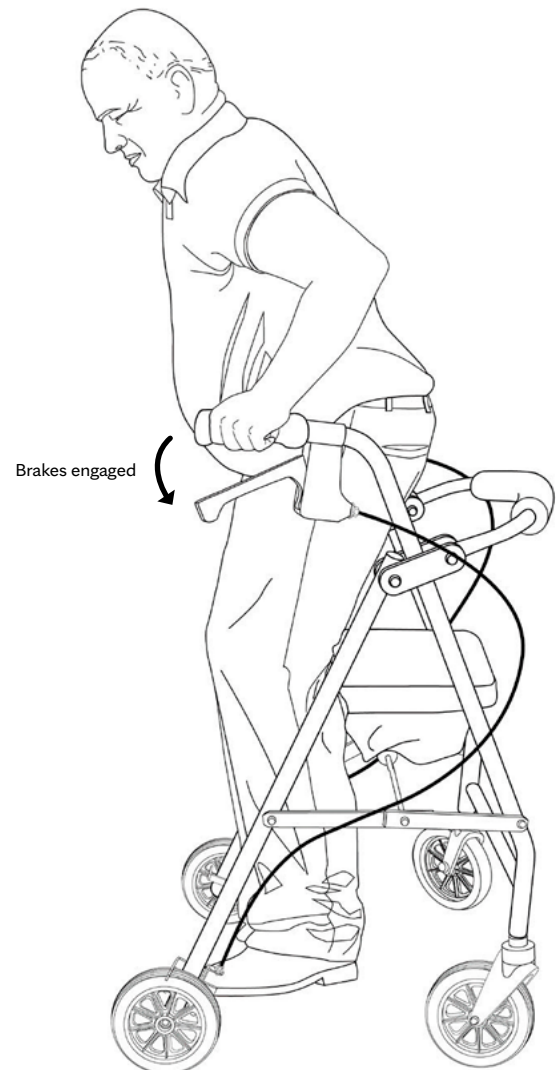
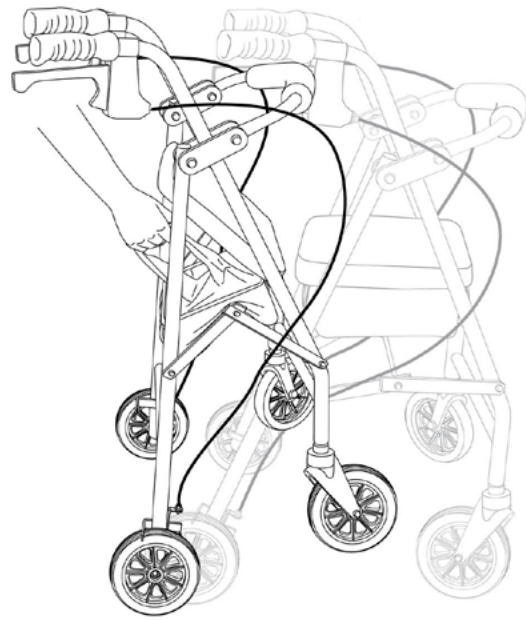

# Knee Scooters

## USAGE INSTRUCTIONS

To ensure the proper and safe use of your knee scooter always:

- 1 Use your good leg to propel your knee scooter.
- 2 Operate your knee scooter with secure footwear (do not use sandals or flip flops).
- 3 When adjusting and/or using your knee scooter, be careful of the positioning of your brake cable.

\* The Mayo Clinic Store team will assist you with the proper fitting of your knee scooter.

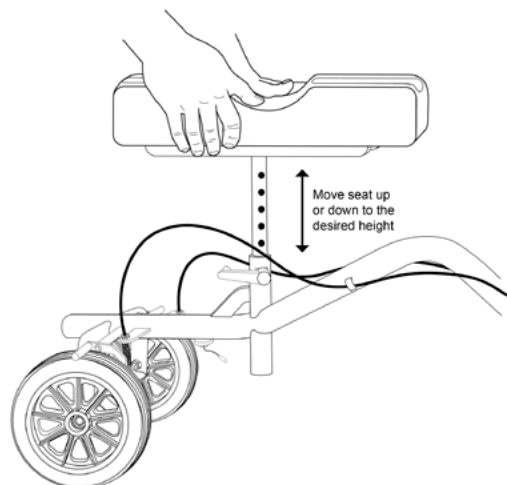
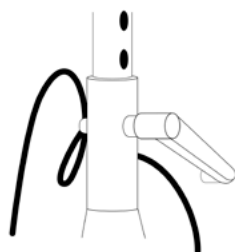
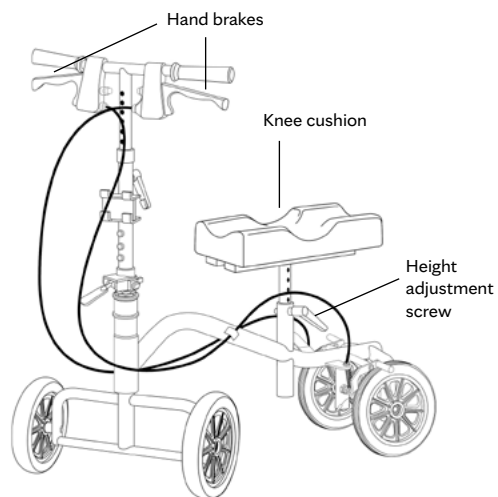

## Folding the Knee Scooter

The steering column of the knee scooter can be released and the handlebars folded down for easier transport. To fold down the steering column:

- 1 Pull up on the release lever that sits at the bottom of the steering column.
- 2 Push the release lever forward.
- 3 Slide the release lever to the right so the pin disengages from the steering column.
- 4 Gently guide the steering column downward and position below the knee platform.

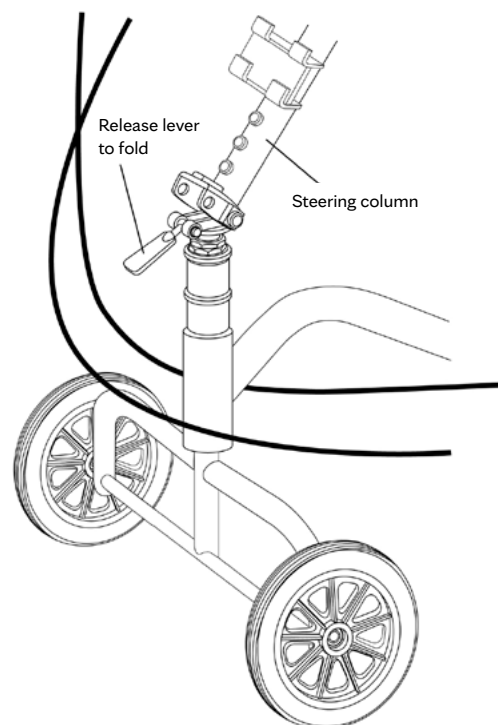
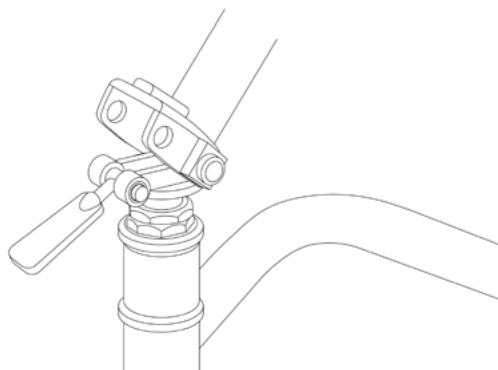

# Crutches

## USAGE INSTRUCTIONS

To ensure the proper and safe use of your crutches always:

- 1 Keep the crutches about six inches away from the outside of your feet. Your elbows should have a slight bend.
- 2 Ambulate by moving both crutches forward before your weaker leg while keeping most of the weight on the palms of your hands.
- 3 Keep the arm pad of your crutches tucked firmly against your rib cage leaving about two finger widths of space between the top of your crutch pad and your armpit. \*Do not rest your armpits on the upper cushions of the crutches or attempt to support your weight in this manner.

\*The Mayo Clinic Store team will assist with the proper fitting of your crutches. If you would like more information on how to fit and navigate with your crutches, please ask for more Mayo Clinic educational material.

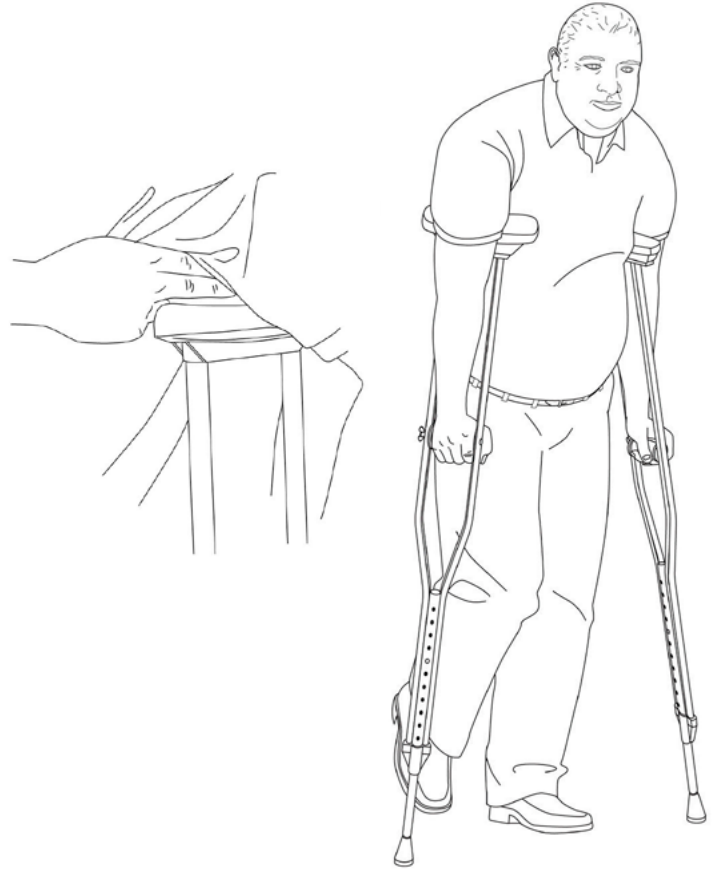

# Canes

## USAGE INSTRUCTIONS

To ensure the proper and safe use of your cane always:

- 1 Make sure it is properly fit to your height.
- 2 Unless instructed by your healthcare team to do otherwise, use the cane opposite the side of your weaker leg or side where you feel pain.
- 3 Your elbow should be bent at about a 20-degree angle when standing upright with your cane.

### Quad Cane Positioning

When using a quad cane, always ensure that the flat side of your quad cane is facing closest to your body.

\*The Mayo Clinic Store team will assist with the proper fitting of your cane. If you would like more information on how to fit and navigate with your cane, please ask for more Mayo Clinic educational material.

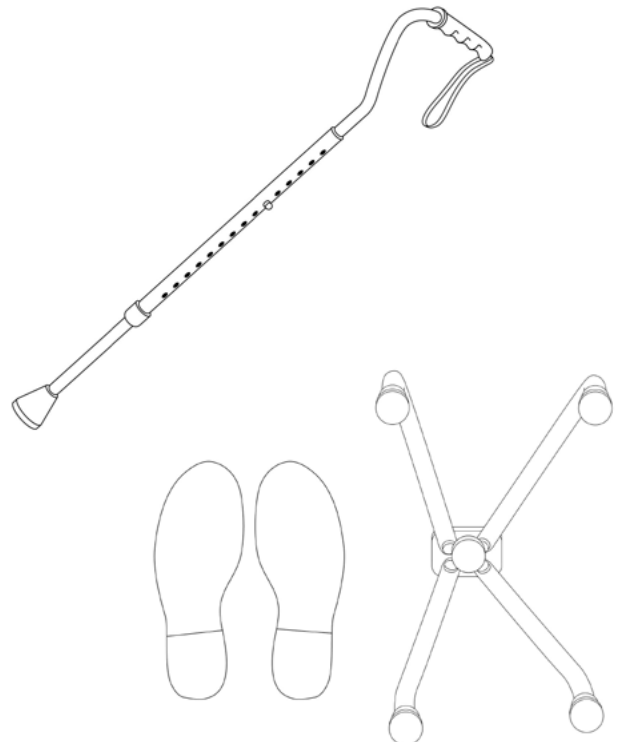

## Additional Instructions for Walkers / Crutches / Knee Scooters / Canes

### CLEANING INSTRUCTIONS

#### As Needed:

- 1 Wash surfaces of the walker with a soft damp washcloth. Avoid the use of abrasive materials (e.g. scouring pads) or abrasive cleaners (e.g. baking soda, Lysol).

### MAINTENANCE INSTRUCTIONS

#### Monthly:

- 1 Check for corrosion, metal bends, or welding cracks.
- 2 Replace rubber tips or hand grips when worn, torn, or loose.
- 3 Check any brass push buttons are in place and not depressed.
- 4 *For four-wheeled walkers and knee scooters:*
  - Check the tension in the hand brakes to ensure the wheels do not roll when brakes are in the locked position.
  - Check that brake lines are still secured into their handles.
  - Check the alignment to ensure it still rolls forward without pulling to one side or the other.
- 5 *For four-wheeled walkers only:*
  - Check that the screw handles securing the walker handles are tight.

### DEVICE TROUBLESHOOTING

If you need assistance troubleshooting your equipment, please contact the Mayo Clinic Store from where you originally purchased or rented it. An easy to reference phone number should be found on your equipment and is available on the first page of this handbook. Most Mayo Clinic Store locations are open 8 a.m. - 5 p.m., Monday-Friday.

Most Mayo Clinic Store locations can provide repairs, replacements, and exchanges during normal business hours.



## SAFE USE INSTRUCTIONS

- Do not attempt to use your equipment as a support device when standing up from a seated position.
- Do not use a chair with wheels. When going to sit, it is recommended you transfer into a stable chair with four legs and keep your mobility aid accessible and within reach.
- Always use your equipment in a manner as prescribed by your medical provider.
- Mobility aids are recommended for use on firm and level surfaces. If using on uneven surfaces, moving sidewalks, stairs, or other inclines, ask your healthcare provider for proper techniques.
- Always be aware of your surroundings so you can avoid common trip hazards such as throw rugs, pets, electrical cords, and wet surfaces.
- Always use caution when adding accessories to your equipment. It is recommended to use manufacturer approved accessories to lessen the risk of injury or damage to your equipment.
- Always consider how any load you may carry will balance against you. For example, a backpack may disrupt your balance if it is too heavy.
- Always be extremely careful on ice, in wet weather, or other dangerous conditions.
- Do not attempt to make repairs to your equipment. To maintain your warranty and lessen potential injury, it is recommended that you contact the manufacturer or the Mayo Clinic Store for assistance.
- Do not attempt to carry items in your hands when using mobility aids.
- Always walk with your head facing forward to maximize your balance.
- Always make sure telescoping legs and hand grips are properly adjusted and secure before use.

---

### When using a walker, four-wheeled walker, or knee scooter:

- Do not attempt to use your equipment if it is not fully locked in the open position.
- Do not attempt to use without both hands on the handlebars.
- Do not extend your upper body or apply excessive weight to the handlebars as they are not intended to support a person's weight.
- Always center your weight and do not lean.
- Do not overload a basket or carry a bag on your equipment. The weight capacity for most models is 10 lbs.

### When using a four-wheeled walker:

- Do not attempt to move yourself or someone else while seated. Do not "scoot" yourself around.
- Always lock the hand brakes before using as a seat, and keep both of your feet flat on the floor.
- Do not attempt to use or sit on this equipment while on stairs, moving sidewalks, escalators, steep inclines, or uneven surfaces.
- Do not extend yourself over the backrest as it is not intended to support a person's weight.
- Do not store sharp objects under walker seats or in your back pockets to avoid puncturing the cushioned material of your seat.
- Always lock the rear wheel brakes before transferring to or from your four-wheeled walker.

### When using a knee scooter:

- Do not "coast" on your knee scooter.
- Always go slowly when operating a knee scooter to maintain control.
- Always slow down when turning to avoid tipping.
- Always lock the rear wheel brakes before mounting or dismounting the knee scooter.
- Do not use your knee scooter cushion as a seat.

# Wheelchairs & Transport Chairs

## CHOOSING A WHEELCHAIR OR TRANSPORT CHAIR

### Wheelchairs

- Wheelchairs are an assistive device for individuals with mobility limitations.
- These chairs have larger wheels with hand rims, which can be self-propelled.
- Wheelchairs also have handles on the back, which allow caregivers to help propel the chair. Wheelchairs may be medically appropriate based on a person's physical condition.
- Wheelchairs come in multiple heights and can accommodate bariatric and reclining needs.

### Transport Chairs

- Transport chairs are lightweight and meant for individuals who will be pushed by a caregiver.
- The small wheels and overall construction of transport chairs are not meant to enable someone to self-propel.

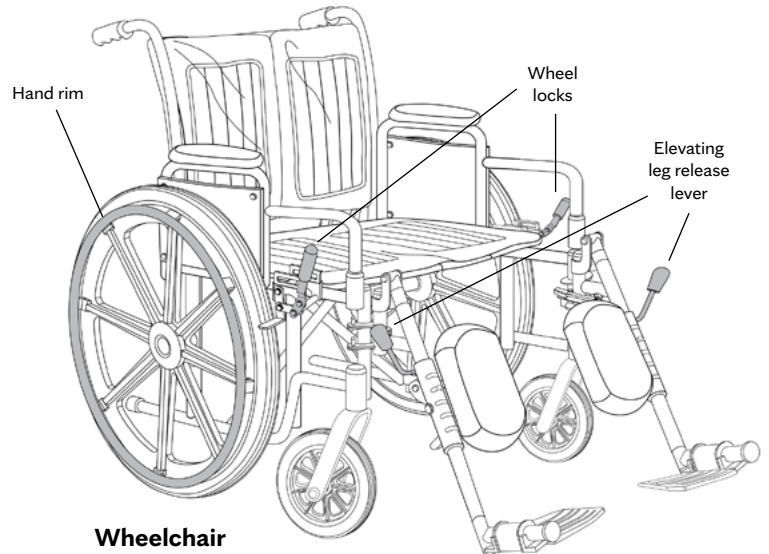

Wheelchair

## USAGE INSTRUCTIONS

### Adding & Detaching Foot and Leg Rests

Foot and/or leg rest options are available on most wheelchairs or transport chairs. Regardless of the type, they may need to be moved out of the way when transferring in and out of the chair. To swing the foot or leg rests out of the way:

- 1 Pull the release lever located under the seat.
- 2 Swing the foot/leg rest towards the outside of the chair.

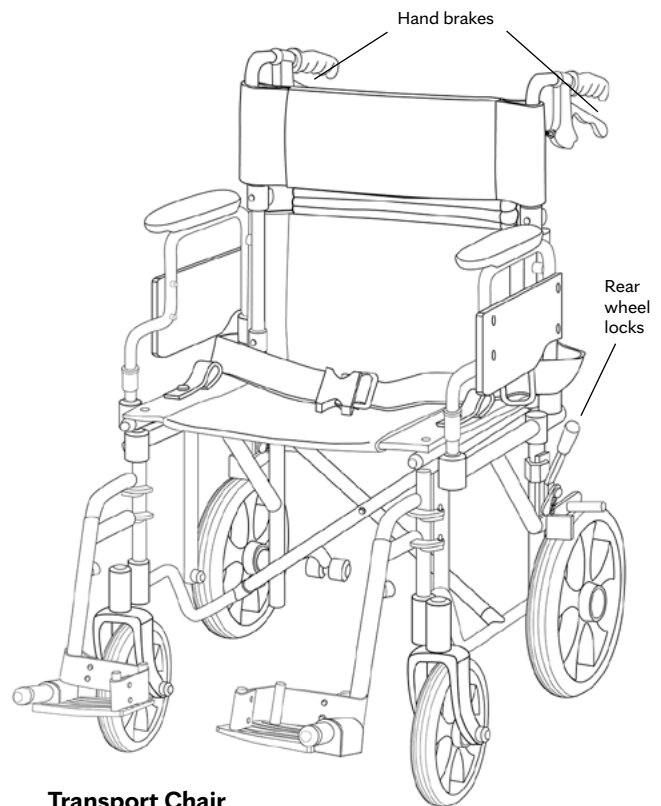
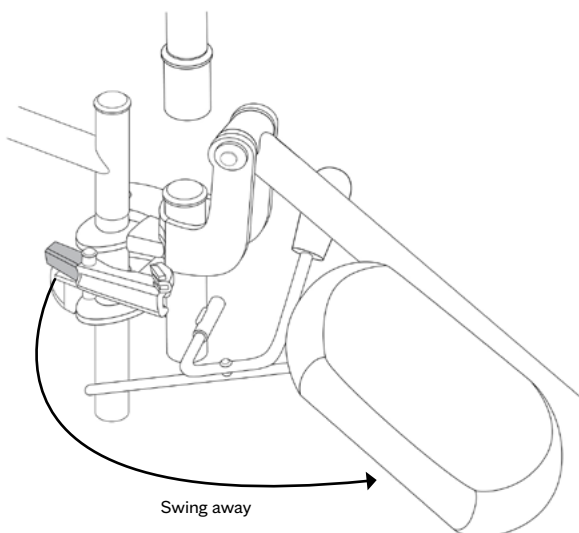

Transport Chair

**If the foot/leg rest needs to be removed, you can:**

- 1 Position the foot/leg rest to the outside of the chair using the release lever located under the seat.
- 2 Lift the bracket attachment.
- 3 Place the foot/leg rest aside.

\*The Mayo Clinic Store team will fit your wheelchair based on your height and weight.

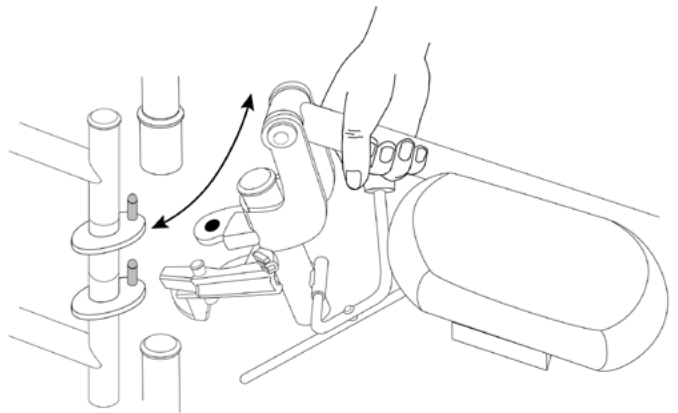

**Using Elevating Leg Rests (Wheelchair Only)**

- Elevating leg rests are fit to your leg for comfort and should not be low enough to cause pressure on your thighs at the front of the seat.
- The length of elevating leg rests can be adjusted.
- The calf pad of the elevating leg rest should be positioned in alignment with the calf. To adjust the pad, use the slide positioning mechanism.
- To raise the elevating leg rest, lift the foot plate to desired height.
- To lower the elevating leg rest, push out on the release lever while at the same time pushing down on the foot rest.

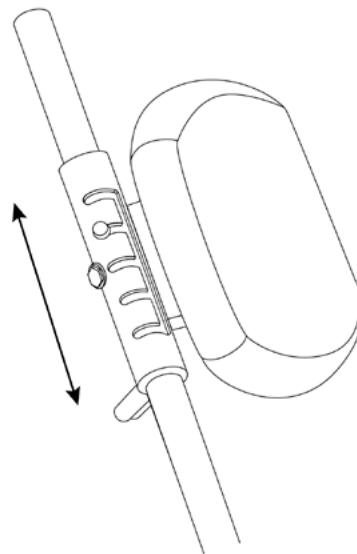

**Wheel Locks**

All wheelchairs and transport chairs come with wheel locks. Wheel locks should be engaged anytime you:

- Sit into the chair.
- Transfer out of the chair.
- Lean forward in the chair.
- Desire the chair to remain in a stationary place.

\*Failure to engage wheel locks while transferring or repositioning can cause you to fall or the wheelchair to roll.

The difference in wheel locks between a wheelchair and transport chair is:

- Wheelchair wheel locks can be engaged by the user.
- Transport chair wheel locks must be engaged by the third-party helper.

\*It is normal for the wheel locks to indent or “bite” into the rubber wheels of the chair.

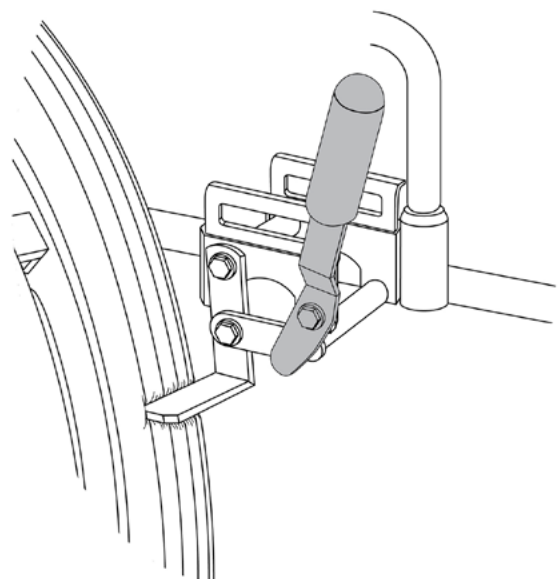

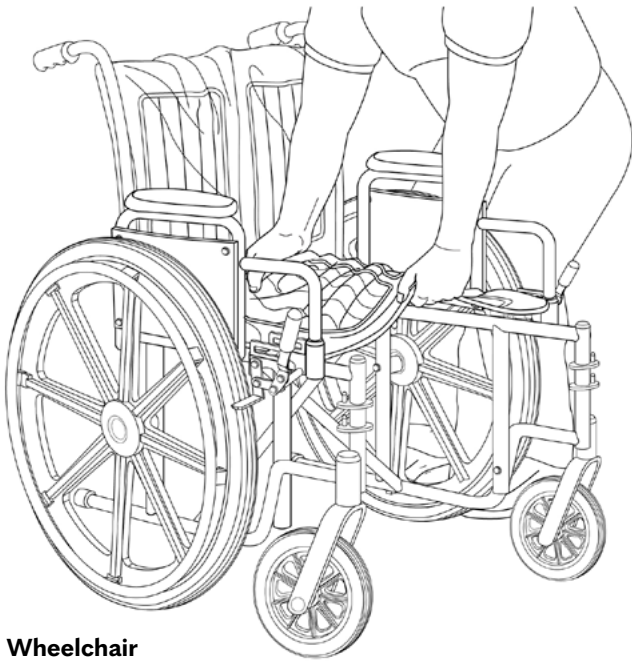

**Wheelchair**

### **Folding the Chair**

All wheelchairs and transport chairs can be folded at the seat for ease of transportation:

*Note: When folding a transport chair, first fold down the upper back part of the chair using the release paddle. Then proceed to the folding instructions below.*

To fold a wheelchair and finish folding a transport chair:

- 1 Stand to the side of the chair.
- 2 Grasp the center of the seat upholstery on the front and back and lift upwards.
- 3 Make sure the chair upholstery comes up until the two sides of the chair collapse together.



**Transport Chair**

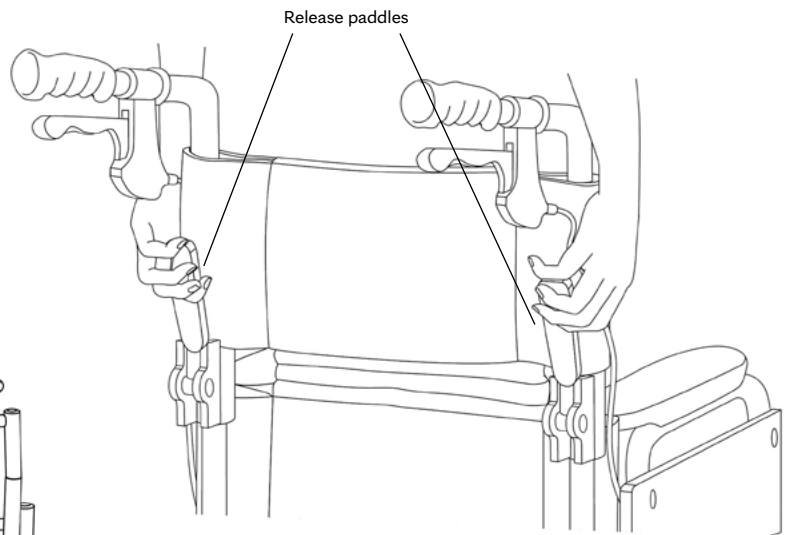



**Wheelchair**

### **Unfolding the Chair**

To unfold a wheelchair or transport chair:

- 1 Stand to the side of the chair.
- 2 Push down on the seat rail until the chair is fully open.
- 3 Check that the seat is firm and flat (note that some wheelchairs have an additional bracket into which the seat rail will lock to ensure it is fully open).

*Note: To finish unfolding the transport chair raise the upper back into the full locking position.*

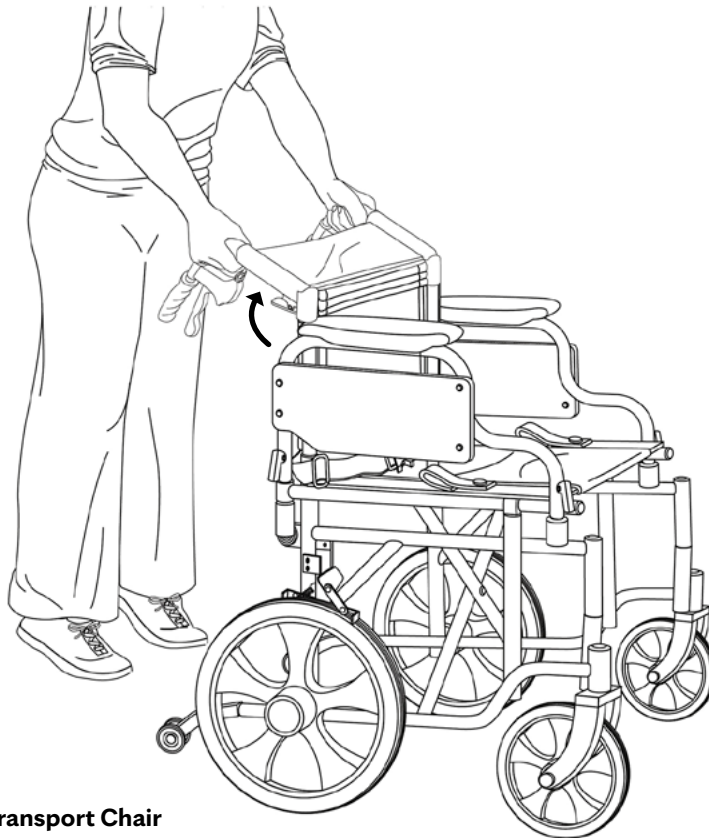

**Transport Chair**

### Wheelchair and Transport Chair Safety Products

Some models of wheelchairs and transport chairs have additional safety products that may be added as needed.

Examples may include:

- Anti-tippers for increase stability when positioning the chair to go up and over inclines and while transferring.
- Lap belts to help keep user positioned properly in the chair.
- Foot and leg rests may help with comfort when riding. Both wheelchairs and transport chairs support foot rests. (Elevating leg rests may be medically necessary and are only available on wheelchairs.)
- Removable arm rests for help with transferring between two even surfaces.

\*The Mayo Clinic Store team will assist with the proper fitting of your wheelchair and will determine the appropriate size of your chair seat based on your current height, weight, and body shape.

### CLEANING INSTRUCTIONS

#### Weekly:

Use a clean cloth to wipe down all aluminum and chrome parts.

#### As Needed:

- Wipe surfaces of the wheelchair with a soft damp washcloth. Avoid the use of abrasive materials (e.g. scouring pads) or abrasive cleaners (e.g. baking soda, Lysol).
- Remove moisture as able.
- Upholstery on the chair can be cleaned with a soft damp washcloth.
- Use only water when cleaning hand grips as chemical cleaners may cause hand grips to lose tension on the chair.



### SAFE USE INSTRUCTIONS

- Always engage the wheel locks into the tires before attempting to transfer in or out of the chair.
- Do not attempt to transfer from your wheelchair or transport chair to a chair with wheels. Always transfer to and from a stable chair with four legs.
- Do not lean your body weight over the back of your chair's upholstery.
- Do not engage wheel locks when reaching for items behind you. In these cases, it is better to let the chair roll than to potentially fall backwards.
- Avoid adding accessories that are not approved by the manufacturer as this may void any product warranty or put your safety at risk.
- Always be aware of your surroundings so you can avoid common hazards such as uneven flooring, power cords, or cracked surfaces which can damage the wheelchair, cause you to lose control, or even to unbalance and tip.
- Be extremely careful on ice, in wet weather, or other dangerous conditions.
- Always receive assistance when navigating steps, inclines, or roadside curbs. Attempting to do these alone or without proper training may result in loss of control or tipping.
- Do not stop and remain stationary in your chair on an uneven surface.

## **MONTHLY MAINTENANCE INSTRUCTIONS**

### **Chair Frame**

- Check for bends, breaks or dents in metal.
- Check for cracked or broken welding.
- Ensure bolts are secure and tight.
- If your chair includes a supportive cross brace underneath the seat, check for bends, breaks, or dents.

### **Chair Upholstery**

- Check for tears or worn areas in the fabric or vinyl.
- Ensure all bolts securing the upholstery are in place and tight.

### **Chair Arm Rests**

- Check the arm for tears or worn areas in the fabric or vinyl.
- Ensure all bolts are in place and secure.

### **Chair Hand Grips**

- Ensure handles are secure and do not wiggle or move.

### **Chair Foot/Leg Rests**

- Ensure foot/leg rest components still secure to the chair and that releases are functioning, not letting any parts move or swing freely.

### **Chair Wheels**

- Ensure bolts and nuts are secure.
- Review spokes and wheels for potential damage or cracks.
- Check alignment by rolling the empty chair forward and ensure it moves straight without pulling to either side (\*issues with alignment or wheel bearings should be completed by a qualified vendor with trained staff).

\*Manufacturers recommend that you consider taking your wheelchair to a qualified vendor with trained staff at least annually for regular service and inspection.



[mayoclinic.org](https://www.mayoclinic.org)

©2025 Mayo Foundation for Medical Education and Research. All rights reserved. MAYO, MAYO CLINIC and the triple-shield Mayo logo are trademarks and service marks of MFMER.

[Learn more online at mayoclinic.org](https://www.mayoclinic.org)

MC1234-158rev0925